

**Direct Healthcare
Group**

Advancing Movement & Health®

Bure XL

Technical Manual



BURE XL

Bure XL

Bure XL was designed for the bigger, heavier patient and therefore provides extra space and strength. Because extra powerful aids are required in the care and nursing of heavier patients, Bure XL is always supplied with electric drives.

Contents

1. Parts list	04
2. Spare parts	06
3. Accessories	06
4. Other instructions	07
5. General maintenance advice	07
6. Safety instructions	08
7. ID label	08
8. Recycling/Scrapping	08
9. Warranty	08
10. Technical specifications	09

1. Parts list

1	A	Armrest	6	M	End bushing/plastic	
	B	Knob		N	Wheel	
	C	Plastic washer		O	Bolt	
		P		Washer		
		Q		Nut		
2	D	Handle and grip	7	R	Washer	
	E	Clamp			Protective plate (left/right)	
	F	Knob				
3		Upper frame		8	S	Remote control
					T	Holder/remote control
4	G	Chromium-plated tube	U		Battery	
	H	Attachment bolt	V		Control box	
	I	Washer	9	X	Actuator (raise/lower)	
	J	End bushing		Y	Bolt, washer (2 pcs), nut (attachment at bottom and top)	
5	K	Frame with battery shelf				
	L	Guide sleeve				

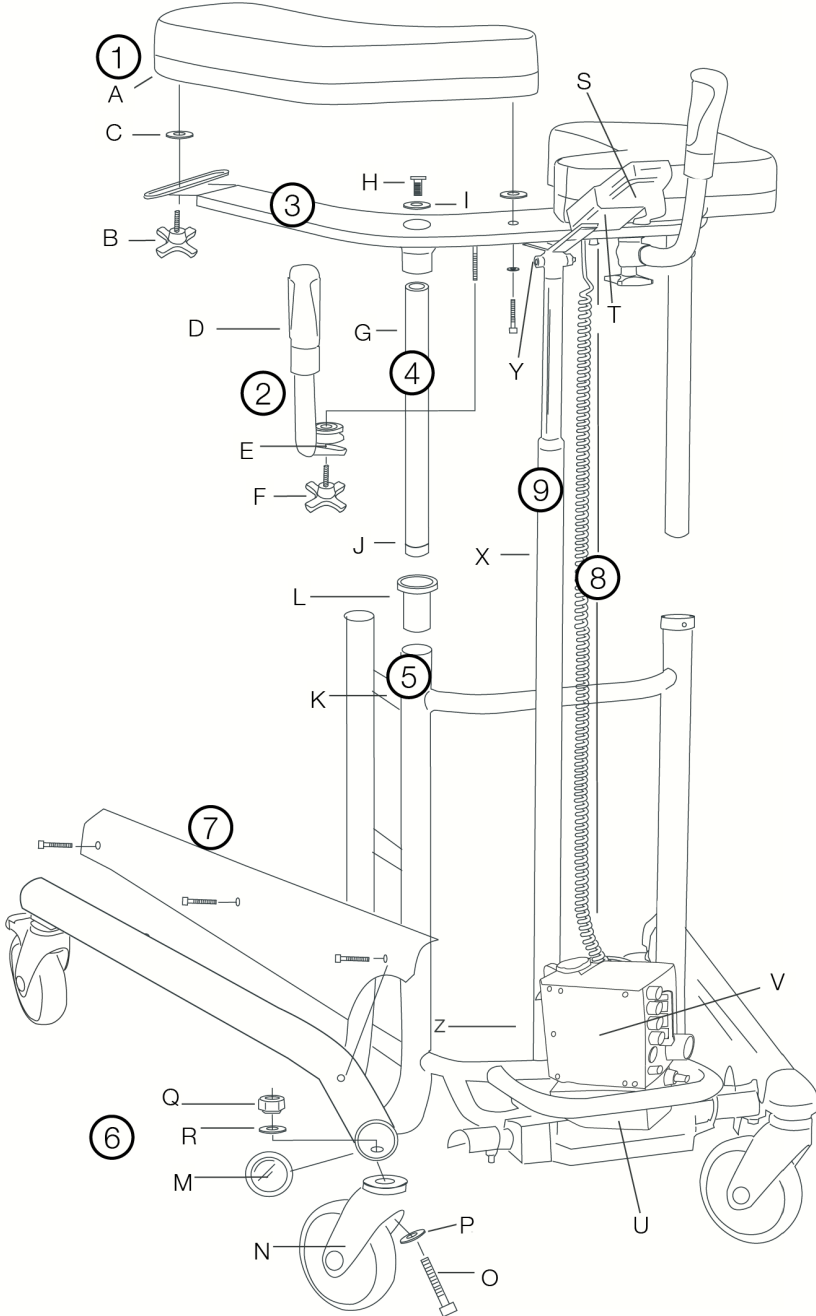

2. Spare parts

No.	Part no.	Description
-	56-305	Touch-up paint Bure, Silver 8
-	56-306	Touch-up paint Bure, Dark grey RAL 7021
1A	57-327	Armrest right
1A	57-328	Armrest left
T	56-328	Holder, hand controller
L	56-340	Guide sleeve
J	56-343	End piece, guide tube
U	56-346-1	Battery/LA31
U	56-346	Battery incl. circuit board/LA28
X	57-004-02	Actuator (raise/lower)/LA31
X	57-004-01	Actuator (raise/lower)/LA28
2	56-353	Handle kit, Bure Std (2 pairs incl. lock knob/clamps)
-	56-357	Wheel without brake 100 mm
-	56-358	Wheel with brake 100 mm
N	56-360	Wheel without brake 125 mm
-	56-361	Wheel with brake 125 mm
-	56-387	Wheel with brake 75 mm
E	56-356	Locking clamp, handle
F	56-363	Knob for adjusting handle
B	56-364	Knob for adj. width of armrest plates
S	56-370-1	Hand control 2channel (raise/lower)/LA31
S	56-370	Hand control 2channel (raise/lower)/LA28
-	56-374-1	Power cable/LA31
	56-374	Charger/LA28
V	56-345-1	Control box 220 V

3. Accessories

Part no.	Description
56-334	Drip holder
56-335	Attachment for drip holder
56-336	Oxygen holder
56-337	Side support, adjustable
56-338	Drip rod complete with attachment
56-386	Footplate, Bure XL (plate)
56-389	Soft basket with attachment

4. Other instructions

Control box wiring

1. Battery terminal socket.
2. Plug socket.
(NOTE: Plugs must ALWAYS be connected to the control box for IP classification to be valid.)
3. Remote control socket.
4. Socket for the raise/lower actuator.

NOTE: Make sure that plugs are connected to the correct sockets otherwise the actuators may be damaged.

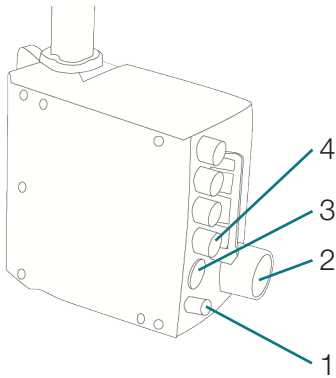

Battery charging

Battery charging must take place when the walker is not in use (the battery can never be overcharged). Charging is carried out by inserting the plug in a wall socket.

The battery should be charged at least 24 hours before first use.

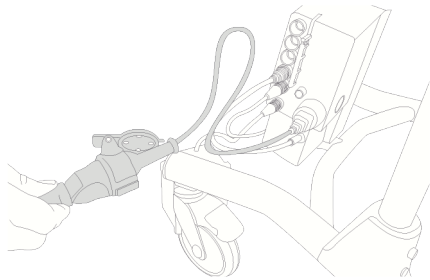

5. General maintenance advice

- Wipe the walker and its armrests clean as necessary; use soap solution.
- The product must ALWAYS feel stable. If the walker is lopsided, squeaks or makes suspicious noises alert personnel.
- Replace damaged parts immediately; must be done by experienced personnel.
- Walkers with electric actuators – NEVER use the walker while charging.
- Make sure the guide tube (4G) is securely tightened in the upper frame (3).

6. Safety instructions

The Bure Walker may only be used:

- As a WALKING AID, indoors
- On HARD, LEVEL surfaces

MAX USER WEIGHT: 240 KG

7. ID label

1. Part number
2. Product name
3. Date of manufacture
4. Max user weight
5. Serial number
6. EAN code

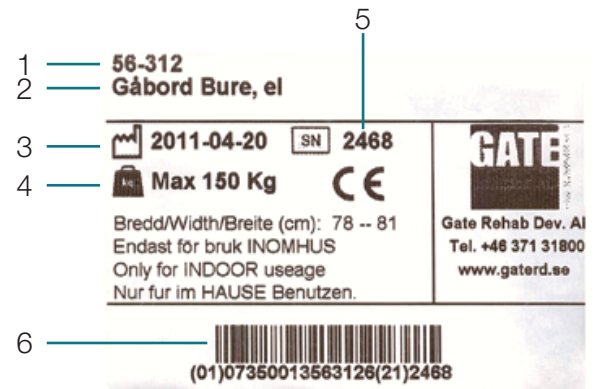

8. Recycling/Scrapping

When the product is no longer usable it should be recycled in accordance with legislation and regulations in the country concerned. All electrical parts including batteries must be removed and recycled as electrical components. (Ask your local recycling station for further information about how the different materials in the product (metals, plastics, electronics) should be recycled).

9. Warranty

We provide two years warranty against manufacturing faults (does not apply to wear parts).

10. Technical specifications

“LIFT” denotes suitable handhold for lifting the walker
NOTE: At least two people are required for lifting.

Product weight: 29 kg
Max user weight: 240 kg

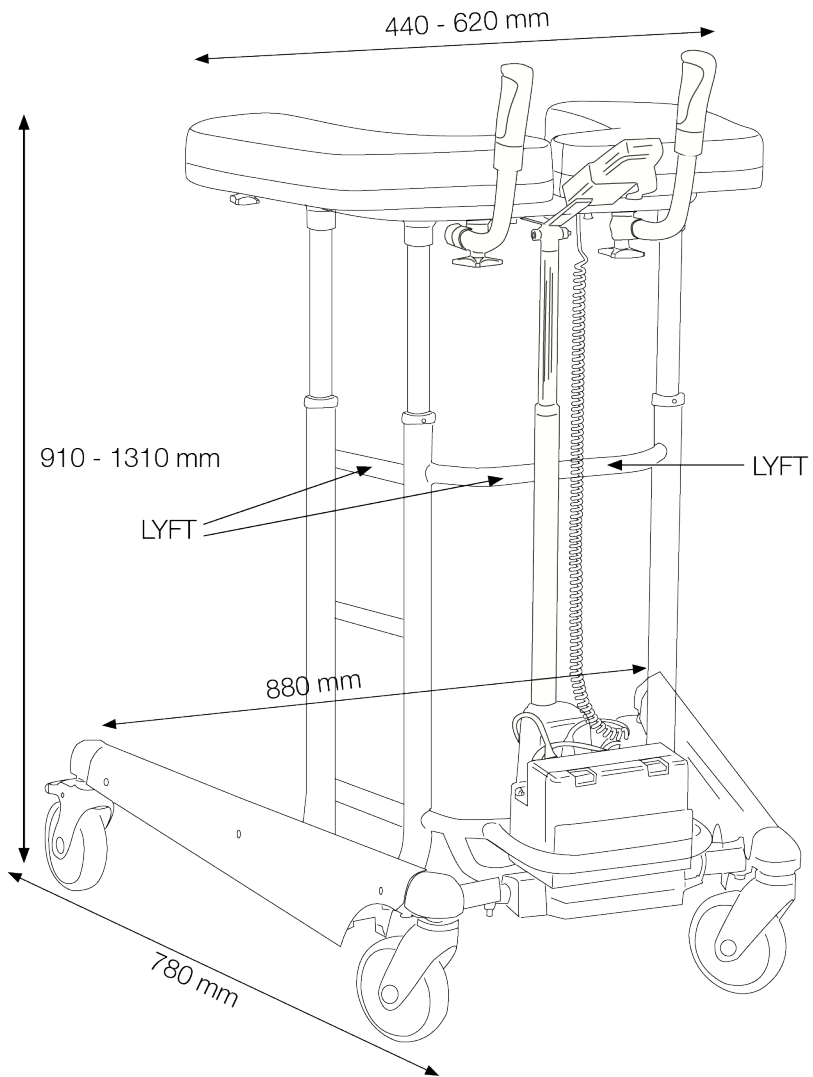

BURE XL

Direct Healthcare Group

Advancing Movement & Health®

Direct Healthcare Group
Withey Court, Western Industrial Estate
Caerphilly
CF83 1BF

T: 0800 043 0881
F: 0845 459 9832
E: info@directhealthcaregroup.com

LIT-00136 Issue 1
Date: January 2020

DIRECTHEALTHCAREGROUP.COM