

Hinged arm support

530/600/700/800/900

Linido

Manual - English

Manual - Svenska

Manual - Norsk

Manual - Dansk

Käyttöohje - Suomi

Gebrauchsanweisung - Deutsch

Handleiding - Nederlands

Manual - Français

Manual - Italiano

Manual - Español

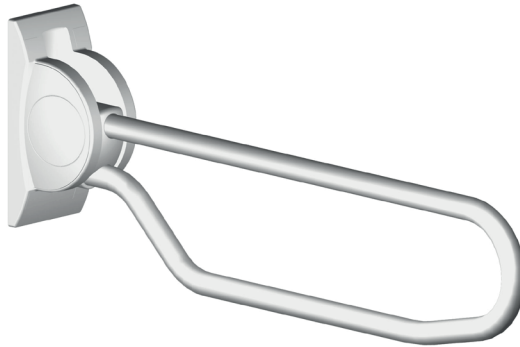

Art.no.

LI2603.3xxx-xx

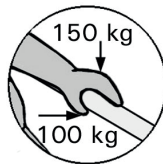

Max: 150 kg/330 lbs

Max: 100 kg/220 lbs

**EN Visual inspection**

Inspect the product regularly. Check to ensure that material is free from damage.

SE Visuell inspektion

Gör regelbundna funktionskontroller av produkten. Kontrollera att materialet är helt fritt från skador.

NO Visuell inspeksjon

Gjør regelmessige funksjonskontroller av produktet. Kontroller at materialet er helt og uten skader.

DK Visuel inspektion

Foretag regelmæssige funktionskontroller af sengebordet. Kontroller, at materiale er helt og ikke udviser tegn på beskadigelse.

FI Silmämääräinen tarkastus

Tarkasta tuotteen toimivuus säännöllisesti. Tarkasta, ettei materiaalissa ole mitään vaurioita.

DE Sichtprüfung

Unterziehen Sie das Hilfsmittel regelmäßigen Funktionskontrollen. Vergewissern Sie sich, daß das Material unbeschädigt ist.

NL Visuele controle

Inspecteer het product regelmatig. Controleer op mogelijke beschadigingen van het materiaal.

FR Inspection visuelle

Effectuer des inspections régulières du fonctionnement du produit. Vérifier que le matériau est entièrement exempt de dommages.

IT Ispezione visiva

Testare il funzionamento del prodotto regolarmente. Verificare che il materiale non sia danneggiato.

ES Inspección visual

Realice periódicamente un control de funcionamiento del producto. Asegúrese de que el material no presente ningún tipo de desperfecto.

EN Before use

Ensure that the product is correctly mounted/installed.

SE Före användning

Kontrollera att produkten är rätt monterad/installerad.

NO Før bruk

Kontroller at produktet er korrekt installert.

DK Før brug

Kontroller, at produktet er korrekt installeret.

FI Ennen käyttöä

Tarkasta, että tuote on asennettu oikein.

DE Vor der Benutzung

Prüfen Sie das Produkt auf korrekte Montage.

NL Voor gebruik

Zorg ervoor dat het product juist is gemonteerd.

FR Avant l'utilisation

Vérifier que le produit est correctement installé.

IT Prima dell'uso

Verificare che il prodotto sia installato correttamente.

ES Antes de su uso

Compruebe que el producto esté correctamente instalado.

**EN Always read the manual**

Keep the manual where it is easily accessible for users of the product.

SE Läs alltid manualen

Förvara manualen tillgänglig för användare av produkten.

NO Les alltid manualen

Oppbevar manualen tilgjengelig for brukere av produktet.

DK Læs altid manualen

Opbevar manualen tilgængelig for brugere af produktet.

FI Lue aina käyttöohje

Säilytä käyttöohje tuotteen käyttäjien saatavilla.

DE Lesen Sie stets die Gebrauchsanweisung

Verwahren Sie die Anleitung so, dass sie der Anwender des Produktes rasch zur Hand hat.

NL Lees altijd de handleiding

Bewaar de handleiding zo dat deze voor gebruikers van het product altijd beschikbaar is.

FR Toujours lire le manuel

Conserver le manuel pour qu'il soit accessible aux utilisateurs du produit.

IT Leggere sempre il manuale

Tenere il manuale delle istruzioni in un luogo facilmente accessibile agli operatori che utilizzano il prodotto.

ES Lea siempre el manual

Guarde el manual en un lugar accesible para el usuario del producto.

Using/Användning/Bruk/Brug/Käyttö/Anwendung/Gebruik/Utilisation/Utilizzo/Empleo

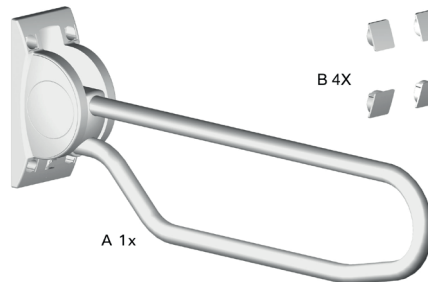

GB: Use proper fixing materials for the wall and resistant to corrosion.

SE: Använd skruvar av rostfritt material. Skruvarna ska vara anpassade till materialet i väggen.

NO: Bruk rustfrie skuer. Skruene skal være tilpasset materialet i veggen.

DK: Använd materialer til væggen, som er korrosions frie.

FI: Käytä kiinnitysruuveja, jotka ovat ruostumatonta terästä. Valitse ruuvityyppi kunkin seinämateriaalin mukaan.

DE: Benutzen Sie Schrauben aus rostfreiem Material und die für die Wand geeignet sind.

NL: Gebruik bevestigingsmaterialen geschikt voor de muur en bestand tegen corrosie.

FR: Utiliser des chevilles adaptées au mur et des fixations inoxydables.

IT: Usare materiali di fissaggio a parete adatti al tipo di muro e resistenti alla corrosione.

ES: Usar tornillos apropiados para cada tipo de pared y que sean anticorrosivos (inox).

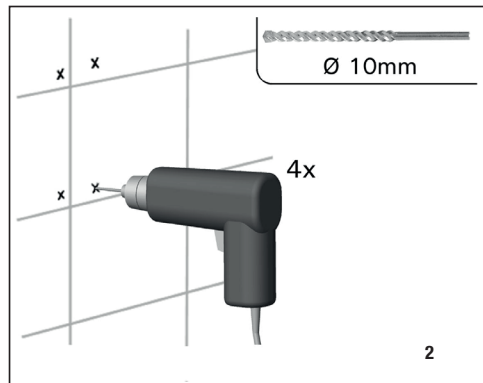
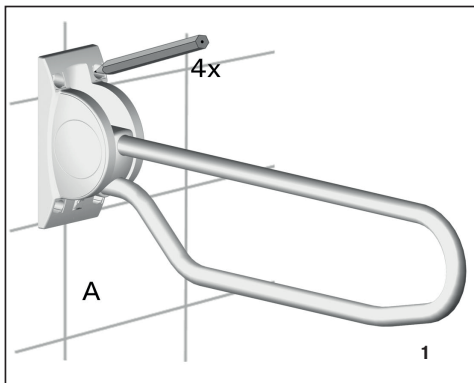

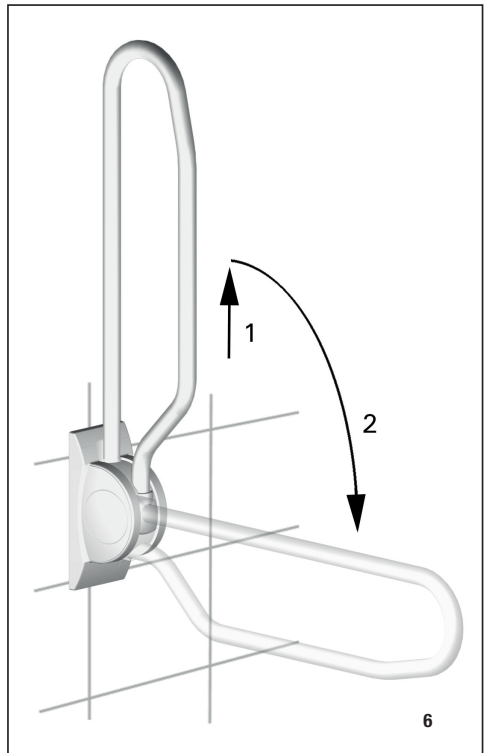
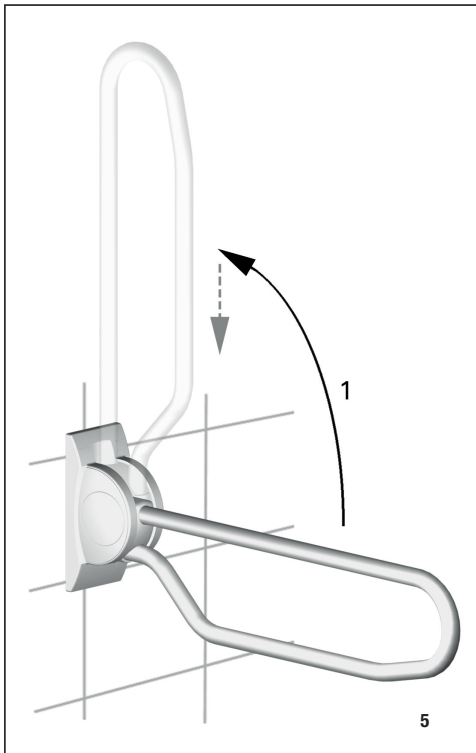
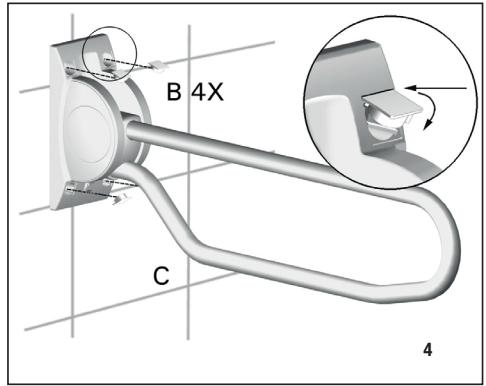
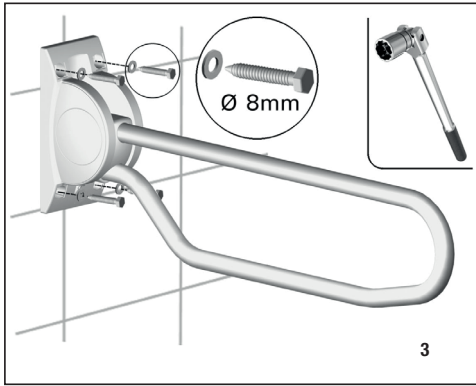

Maintenance/Rengöring/Vedlikeholdsråd/Vedligeholdelse/Hoito-ohje/Pflegeanleitung/ Onderhoud/Conseils d'entretien/Cura del prodotto/Cuidado del producto

EN Clean regularly with normal household detergent. Do not use aggressive cleaners.

Direct Healthcare Group is not liable for damage caused by improper mounting/use.

SE För rengöring använd normalt och inte aggressivt rengöringsmedel.

Direct Healthcare Group står ej ansvarig för skador som uppstår pga. felaktig montering/användning.

NO For rengjøring bruk nøytralt/normalt rengjøringsmiddel og ikke etsende midler.

Direct Healthcare Group står ikke ansvarlig for skader som kan oppstå pga feilaktig motering/bruk.

DK Efter brug tjernes sæberester. Der må ikke anvendes hårde rengøringsmidler.

Direct Healthcare Group er ikke ansvarig for skader opstået pga. torkert montering/brug.

FI Puhdista säännöllisesti käyttäen kodin yleispuhdistusaineita. Älä käytä voimakkaita liuottimia.

Direct Healthcare Group ei ole vastuussa vahingosta, joka johtuu virheellisestä asennuksesta tai käytöstä.

DE Beseitige nach Benutzung Seifenreste. Kein aggressives Reinigungsmittel verwenden.

Direct Healthcare Group ist nicht haftbar für Schäden die durch unsachgemässe Befestigung/Benutzung oder falsches Befestigungsmaterial entstanden sind.

NL Verwijder na gebruik zeepresten. Gebruik geen agressieve schoonmaakmiddelen.

Direct Healthcare Group is niet aansprakelijk voor schade als gevolg van onjuiste bevestiging/gebruik.

FR Laver régulièrement avec un détergent ménager. Ne pas utiliser de détergent agressif.

Direct Healthcare Group n'est pas responsable des dommages causés par un montage/utilization incorrect.

IT Pulire periodicamente, utilizzando detersivi di uso corrente per la casa. Non usar prodotti abrasivi e corrosivo.

Direct Healthcare Group non è responsabile per i danni causati dal montaggio/uso improprio.

ES Limpiar regularmente con cualquier detergente no corrosivo. No usar lejía ya que es muy corrosivo.

Direct Healthcare Group no se hace responsable de cualquier deterioro causado por un montaje/uso incorrecto.

Accessories/Tillbehör/Tilbehør/Lisävarusteet/Zubehör/Accessoires/Accessori/ Accesorios

Art. no:	Product name:	Description:
LI2806.0000-00	Wall mounting set	Fixing mount, for wall mounting of all variants of Hinged arm support, for 1 wall plate.
LI0126.5014-02	Backing plate rectangular	For secure fixing to a weaker wall, for all variants of Hinged arm support, for 1 wall plate.
LI2609.2003-02	Front support bar	750 mm, adjustable length, for all variants of Hinged arm support.
LI2910.0010-00	Soft armrest	Length 350 mm, for all variants of Hinged arm support.
LI2614.300x-xx	Floor support for arm support	Height adjustable, for all variants of Hinged arm, support except LI2603.350x-xx.
LI2615.3004-xx	Height adjustment system	For all variants of Hinged arm support, for 1 arm support.
LI2608.000x-xx	Floor console for arm support	For floor mounting, height 1000 mm, for all variants of Hinged arm support.
LI2917.0002-03	Toilet roll holder	Stainless steel and plastic, black clamp, for all variants of Fixed arm support.
LI2618.0006-02	Toilet roll holder single-hand	For single handed use, plastic, white, for all variants of Fixed arm support.
LI2826.0036-xx	Cover set	Spare part, for Hinged arm support LI2603.3xxx-xx, for 1 arm support.

Dimensions/Måttbeskrivning/Målbeskrivelse/Mitat/Maßbeschreibung/Afmetingen/ Dimensioni/Dimensiones

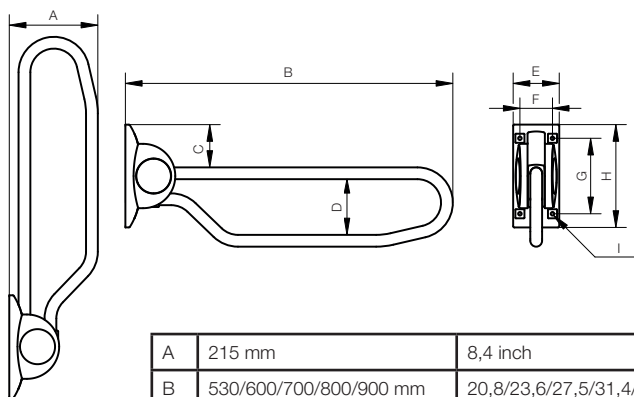

A	215 mm	8,4 inch
B	530/600/700/800/900 mm	20,8/23,6/27,5/31,4/35,4 inch
C	105 mm	4,1inch
D	135 mm	5,3 inch
E	110 mm	4,3 inch
F	79 mm	3,1 inch
G	183 mm	7,2 inch
H	250 mm	9,8 inch
I	Ø8,6mm	Ø0,3 inch

Linido

Direct Healthcare Group's Linido product line is a wide range of high quality safety products designed to provide ergonomic support, comfort and increased independence for the user in various bathing, showering and toileting situations.

Contact your local distributor if you have any questions about the product and its use.

See www.directhealthcaregroup.com for a complete list of distributors.

Always make sure that you have the right version of the manual.

The most recent editions of manuals are available for downloading from our website, www.directhealthcaregroup.com

Direct Healthcare Group

Advancing Movement & Health®

Direct Healthcare Group
Withey Court, Western Industrial Estate
Caerphilly, United Kingdom
CF83 1BF

Tel: +44 (0) 800 043 0881
info@directhealthcaregroup.com
www.directhealthcaregroup.com