

Castor

SystemRoMedic™



*Compact, discreet
and very stable*

Lifts up to 300 kg/660 lbs

*Safe and flexible lifting
solutions for all settings*

Castor is a safe, high-performance and portable freestanding lift stand, which together with a rail and a lift unit, functions as a stationary lift system. Castor is made of aluminium, which makes it light in relation to its large, 300 kg/660 lbs lifting capacity. The design is both compact and discreet while at the same time making Castor one of the sturdiest freestanding lift stands on the market. Castor is very easy to assemble and disassemble and therefore easy to move to locations where there is a need for lifting. With Castor, you can create many safe and flexible lifting solutions that are ideally adapted for all settings and users.

Rail ordered separately. The lift stand pictured is equipped with extra locking handles, which are available as an accessory.



Castor

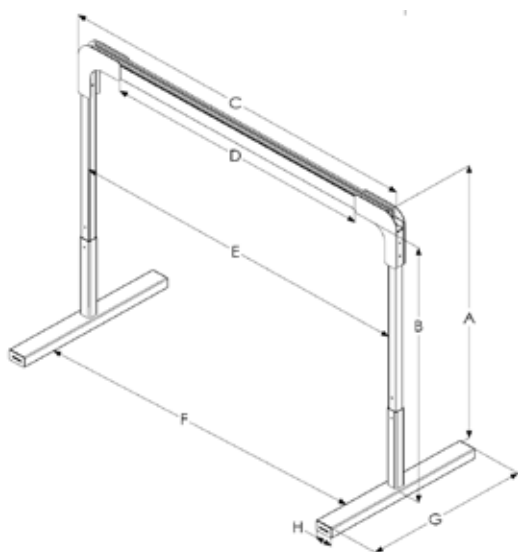

TECHNICAL INFORMATION

A Height, total:	_____	200-244 cm / 78.74-96.06"
C Width, total:	_____ *)	200-700 cm / 78.74-275.59"
E Width, between uprights:	_____ *)	209-709 cm / 82.28-279.13"
F Distance between supporting feet:	_____ *)	204-704 cm / 80.31-277.16"
G Length, supporting foot:	_____	120 cm / 47.24"
H Width, supporting foot:	_____	13 cm / 5.11"
B Lifting range, height:	_____	192-227 cm / 75.59 - 89.37"
D Lifting range, width:	_____ *)	223-723 cm / 87.79-284.64"
Weight, total:	_____ *)	49,6-86,4 kg / 109.3-23,5 lbs
Safe working load:	_____	300 kg / 660 lbs

*) Depending on rail length



Product specifications:

Castor, freestanding lift stand, aluminium, white __ Art. No. 50300004 *without rail*

Rail-64, aluminium, white _____ Art. No. 50400262 - 50400266 *ordered separately*

Rail-120, aluminium, white _____ Art. No. 50400277 - 50400290 *ordered separately*

Rail-160, aluminium, white _____ Art. No. 50400295 - 50400299 *ordered separately*

Accessories:

Locking handles, quick release, 4 pcs _____ Art. No. 50300006

Stationary lift systems are lift units that are mounted either on a ceiling rail system or on a freestanding lift stand. This is an ergonomically ideal alternative, since the system is always in place, it takes up minimal floor space and it is very easy to manoeuvre. Another advantage is that the system gives you a large lifting area and the possibility of both low and very high lifting.

Castor is a freestanding lift stand, which together with a rail and a lift unit, functions as a stationary patient lift system. It is ideal for occasional lifting needs in a specific location, or where it is not possible to install a permanent rail system on the ceiling.

Low weight and high lifting capacity

Castor is made of aluminium, which makes it light in relation to its large lifting capacity (up to 300 kg/660 lbs). The design is both compact and discreet while at the same time making Castor one of the sturdiest freestanding lift stands on the market. Its strength and stability make it safe and secure for the user and the caregiver.

Easy to assemble, move and store

Castor consists of three main components: supporting feet, uprights with corner pieces and a rail.

Castor is very easy to assemble and disassemble and therefore easy to move to locations where there is a need for lifting. The rail is mounted quickly and easily with bolts. To make mounting of the rail even easier, the bolts can be replaced with locking handles, which are available as an accessory. The separate pieces are light and the uprights are equipped with practical carrier handles.



Flexible width and height of lifting range

With Castor, you can create many safe and flexible lifting solutions that are ideally adapted for all settings and users. The rail is ordered separately, which allows you to choose the rail length and thereby adapt the lift stand's width and the lifting range width to optimally meet lifting needs in different settings. Rails are available in lengths from 2-5 metres.

With the help of double locking handles on the uprights, the height can be easily set at three different positions to adapt the lift stand and lifting range height according to the specific situation and lifting needs. With the same lift stand, it is also possible to perform both low and very high lifts.



Castor can be used in combination with different types of lift units. Depending on the requirements for lifting capacity, the settings and situations in which the lift system will be used and the users' needs, you can select either a portable lift unit with a separate carriage and external charger or a permanent lift unit with built-in carriage and rail-mounted charger.

SystemRoMedic lift units and lifting accessories

Castor can be used in combination with SystemRoMedic lift units and many smart and functional lifting accessories in the SystemRoMedic range of products for safe and easy transfers. For example, sling bars and slings adapted for different types of lifts and for users with different lifting needs.

For more information, please visit www.handicare.com. Always read the manual and remember that lifting accessories must be properly fitted and tested in relation to the user's needs and functional ability.

SystemRoMedic™ is a complete solution for easy transfers. The concept encompasses four product areas that meet most needs in different transfer situations.

Transfer, between two locations. **Positioning**, within the same location.

Support, for mobility. **Lifting**, both manual and mechanical.



handicare

Handicare AB
Torshamnsgatan 35,
SE 164 40 Kista, SWEDEN
Tel: +46 (0)8-557 62 200
Fax: +46 (0)8-557 62 299
www.handicare.com
info@handicare.se